



RACING INSTINCT



«Passione, Conoscenza, Ambizioni».

Fondata nel 2000, Atech Racing nasce dalla volontà dei soci fondatori di creare una filosofia «centrata sui piloti» negli accessori per gli sport motoristici. Prodotti di qualità, realizzati con le migliori tecnologie e materiali più sicuri, che hanno permesso al marchio di crescere rapidamente e di affermarsi come marchio di successo nel mercato globale. Oggi Atech Racing è un marchio noto e stimato, che vanta un catalogo molto attraente grazie ai suoi prodotti in stile riconoscibile.





11

RACING SUITS

21

UNDERWEAR SUITS

25

GLOVES

27

PILOT SHOES

29

MECHANICS SUITS

37

SEATS

77

BELTS

81

STEERING WHEELS

85

ACCESSORIES





SNAP INTO A RACING
SUIT AND PLAY A SAFE



tech
racing

tech

note®
al tuo fianco

WHEEL
SISTERS
FOR POWERGIRLS

Stoholm
Au2service
Lundmarkstråke TV 48-5017-5028

Langå Bilsyn

J. Kvick

note®
naviga al tuo fianco



RACING SUITS

Our racing suit, personally designed by our technicians, are extremely comfortable as well as being created with high quality fireproof materials. They can also be customized as desired.



NEW DESIGN



NEW SUIT

Complies with
(Fia Standard 8856-2018)

Sizes: 44 / 66

3 layers, 1 layer 100% Nomex lightweight cloth,
3D honeycomb interior for greater breathability,
internal pockets, elasticated parts
on the back and armholes
for greater comfort



atech
racing

atech
racing

atech
racing

SUITS NEW CHALLENGE

Complies with
Fia Standard 8856-2000

Sizes: 44 / 66

Professional fireproof atech overall derive form experience in top level competitions and is and excellent combination between materials lightness and optimale transpiration thanks to new Honey comb internal tissue.

Fabric weight: 345g/mq | External fabric:
Twill, 100% Nomex high resistance to usury and peeliñg
Lining: high breathable honey comb knitted fabric | 100%
Aramidic Sleeves: in aramidic knitted fabric for optional comfort.





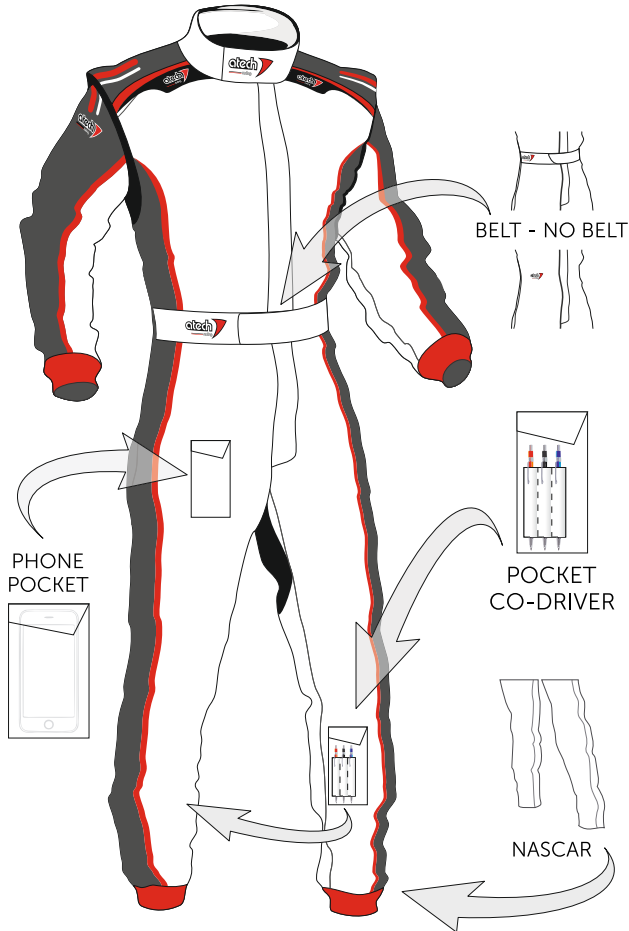

MODIFICATIONS, ACCESSORIES, COLORS

We can satisfy all your requests, with accessories for the pilot and the co-pilot and a wide range of colors.



PHONE POCKET



POCKET CO-DRIVER



COLOR CHART

Standing 2058 2000
RS.199.11
atech
Year of manufacture. 2019

atech
racing

CAVE



TRAILHEAD
GENT
JERKY

MADE
IN WALES
TRAILHEADFINEFOODS.CO.UK

STANDARD SUIT SIZE CHART

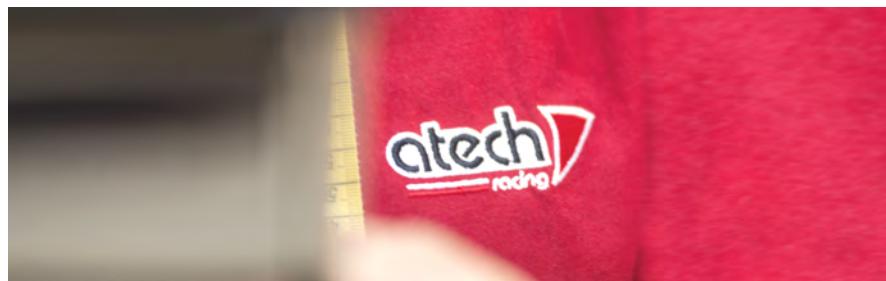
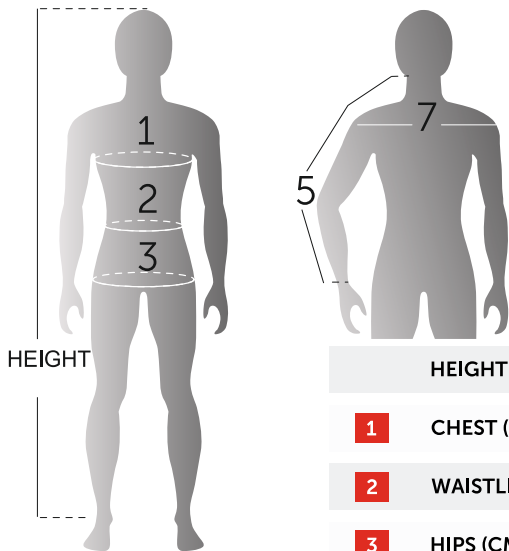

	44	46	48	50	52	54	56	58	60	62	64	66
HEIGHT (CM)	163,0	166,0	169,0	173,0	176,0	179,0	182,0	186,0	189,0	192,0	196,0	199,0
1 CHEST (CM)	88,0	92,0	96,0	100	104,0	108,0	112,0	116,0	120,0	124,0	128,0	132,0
2 WAISTLINE (CM)	72,0	76,0	80,0	84,0	88,0	92,0	96,0	100,0	104,0	108,0	112,0	116,0
3 HIPS (CM)	85,0	89,0	93,0	97,0	101,0	105,0	109,0	113,0	117,0	121,0	125,0	129,0
5 ARM (CM)	53,5	54,5	55,5	56,5	57,5	58,5	59,5	60,5	61,5	62,5	63,5	64,5
7 SHOULDERS (CM)	42,4	43,6	44,7	45,9	47,0	48,2	49,3	50,5	51,6	52,8	53,9	55,1



J. Kvick

UNDERWEAR SUITS

UNDERWEAR

Complies with

Fia Standard 8856-2000 / 8856-2018

Sizes: S - M - L - XL - XXL

Fia approved atech fireproof underwear range is able to meet the needs of all driver, from entry level models to body fit.



A-UW005

A-UW19 BALACLAVA



A-UW001

A-UW 19 BALACLAVA



MANUFACTURER: ATECH
MODEL: A-UW 19 BALACLAVA
FIA STANDARD: 8856-2018

NEW DESIGN



NEW



A-UW 002
A-UW19 TOP



A-UW 006
A-UW19 TOP



A-UW 003
A-UW19 PANT



A-UW 007
A-UW19 PANT





NEW DESIGN



GLOVES ATG001

Complies with
Fia Standard 8856-2000

Racing Glove, Fireproof,
with silicone prints on the palm
and fingers that give a good grip:

Lightweight, good grip,
external seams for maximum sensitivity.
The wrist is a stretch to fit optimal.



RED



WHITE



BLUE



BLACK

NEW DESIGN



APPROVED

MANUFACTURER: ATECH
MODEL: ATG001
FIA STANDARD: 8856-2000



Energy

altech
racing

altech
racing

6-1000-500-1122

PILOT SHOES **ATSH001**

Complies with
Fia Standard 8856-2000

Fireproof ankle boot with upper in suede leather, non-slip rubber sole and footbed with wide shapes to give maximum confort over time.

Color : Black Red



Nomex sock **A.ST 012**

Color: White



MECHANICS SUITS

Professionalism, resistance but at the same time comfort,
our suits make the job of the mechanic more secure and practical.
In touch with tomorrow.

A close-up photograph of a dark, textured fabric, likely a piece of clothing, showing horizontal stitching lines. The lighting is soft, highlighting the texture and the details of the thread.

QUALITY YOU CAN WEAR

MECHANICS OVERALLS

A.TT 0301 OVERALLS

Sizes: 44 / 64

In cotton and polyester with internal neck/back/sleeves in knitted fabric | Reinforcements of knees and elbows | Comfortable front pockets | Elastic cuffs | Open bottom leg for optimal comfort Design directly derived from driver suits, high wear resistance with best comfort during daily use.







MECHANICS OVERALLS

A.TT 0300 OVERALLS

Sizes: 44 / 64

Design directly derived from driver suits, high wear resistance with best comfort during daily use.

In cotton and polyester with internal neck/back/sleeves in knitted fabric | Reinforcements of knees and elbows |

Comfortable front pockets elastic cuffs | Open bottom leg for optimal comfort.

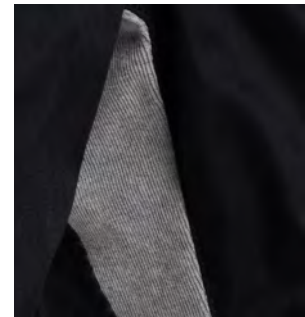





A.TT 0300 OVERALLS

atech
racing
TOM CAVE





SEATS

Our racing suit, personally designed by our technicians, are extremely comfortable as well as being created with high quality fireproof materials. They can also be customized as desired.

NEW CARBON
SEATS FIA 8862-2009

atech
racing

atech

ADVANCE-LINE
CARBON FIBRE

CARBON RS LHT

ATCRS9 190 LHT

Complies with Fia Standard 8862-2009

Weight: 9,750 kg

Total weight: 11,300 kg



CARBONTECH



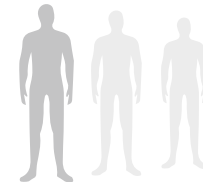

The Atech CARBON RS LHT: has passed the stringent requirements of the standard FIA 8862-2009, designed for the new generation car, ideal for tall pilots, over 190 cm, its ergonomic shape allows a large integration in cars.

- Carbon shell
- Side head protection
- Preformed shell with ASS (Anatomic shell System)
- New seat belt slot fixed to the shell
- Velour covering
- Technical insert
- 5 seat belt opening
- Lateral fixing

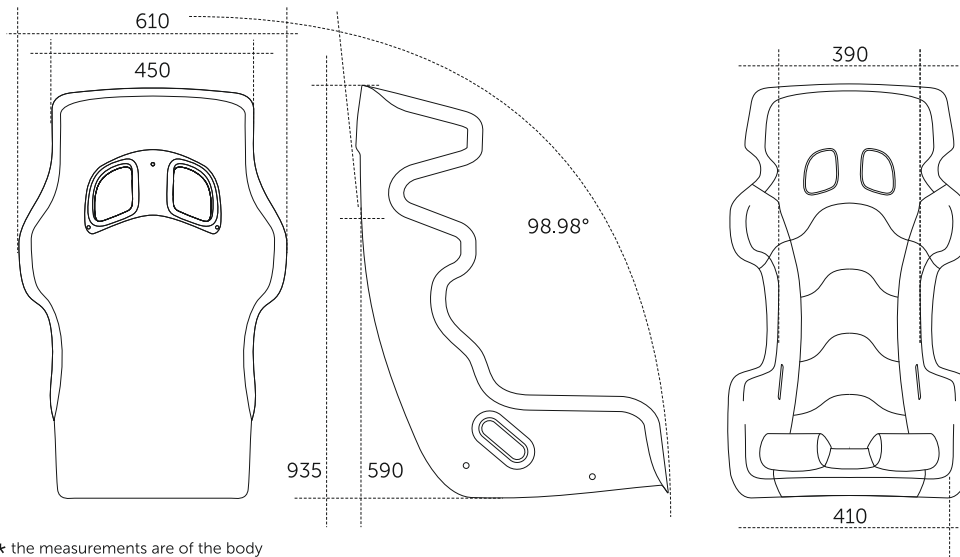

★ the measurements are of the body therefore without sponge

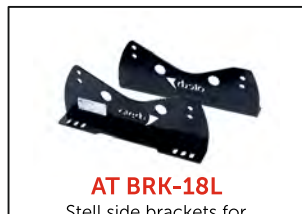

AT BRK-18L

Stell side brackets for use only with RS/RS8/LHT carbon seats

CARBON RS8 LHT

ATCRS8 180 LHT
Complies with Fia Standard 8862-2009

Weight: 9,450 kg
Total weight: 10,900 kg



CARBONTECH



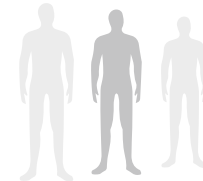

Sizes: L

The Atech CARBON RS LHT: has passed the stringent requirements of the standard FIA 8862-2009, designed for the new generation car, ideal for tall pilots, over 185 cm, its ergonomic shape allows a large integration in cars.

- Carbon shell
- Side head protection
- Preformed shell with ASS (Anatomic shell System)
- New seat belt slot fixed to the shell
- Velour covering
- Technical insert
- 5 seat belt opening
- Lateral fixing

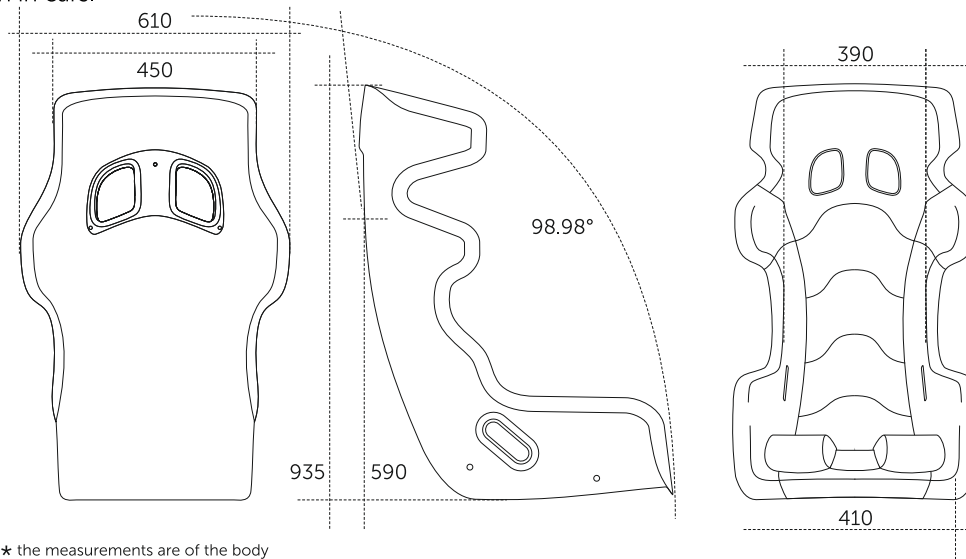

★ the measurements are of the body therefore without sponge



AT BRK-18L

Stell side brackets for use only with RS/RS8/LHT carbon seats

CARBON RS7 LHT

ATCRS7 170 LHT

Complies with Fia Standard 8862-2009

Weight: 9,250 kg

Total weight: 10,600 kg



CARBONTECH



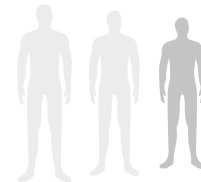

Sizes: **M**

The Atech CARBON RS LHT: has passed the stringent requirements of the standard FIA 8862-2009, designed for the new generation car, ideal for tall pilots, over 175/180 cm, its ergonomic shape allows a large integration in cars.

- Carbon shell
- Side head protection
- Preformed shell with ASS
(Anatomic shell System)
- New seat belt slot fixed to the shell
- Velour covering
- Technical insert
- 5 seat belt opening
- Lateral fixing

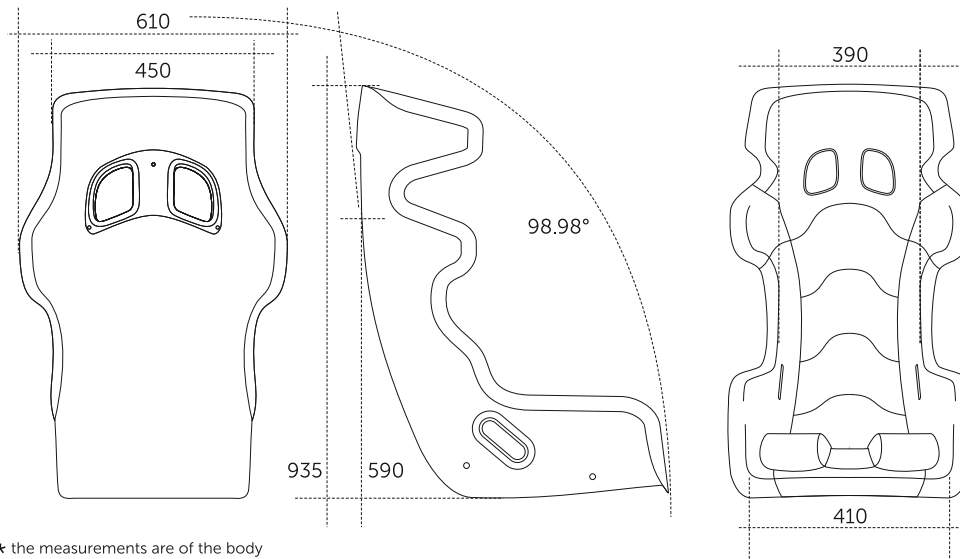

★ the measurements are of the body therefore without sponge



BRK C-RS

Stell side brackets for use only with RS/RS7 carbon seats



blech

ing insti



MAROSO
AUTOCLAVES



racing instin



NORTH ATSPEX033

Complies with Fia Standard 8855-1999



NEW DESIGN



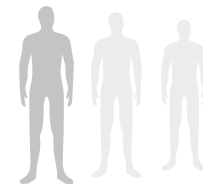

Sizes: **XL**

Developed on the Extreme S2 seat's project, North Seat due to special ergonomic changes proves to be very suitable for riders taller than 185 cm.

- Gellcoated fiberglass shell
- Side head protection
- Preformed shell with ASS (Anatomic shell System)
- New seat belt slot fixed to the shell
- Velour covering
- No slip cushion
- Technical insert
- 5 seat belt opening
- Lateral fixing
- Weight: 8,600 kg

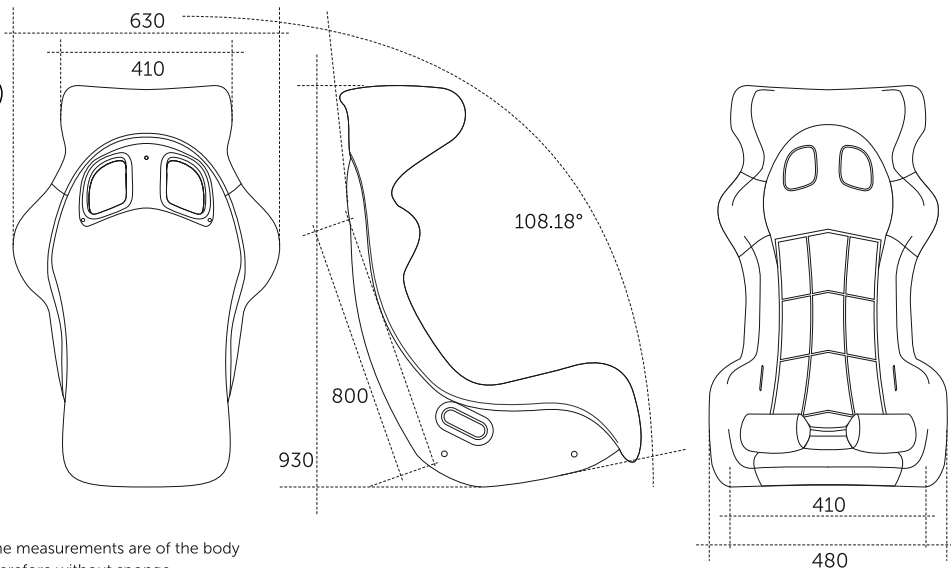

★ the measurements are of the body therefore without sponge



ATAC 0318

Stell side brackets for all other seats

EXTREME S2 ATSPEX032

Complies with Fia Standard 8855-1999



THE ORIGINAL



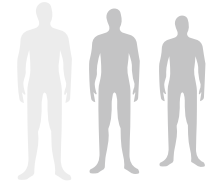

Sizes: **L/M**

Seat born the profile is taken to the extreme form to be placed in very limited cockpits, suitable for rider up to 180cm.

- Gel-coated fiberglass shell
- Side head protection
- Preformed shell with ASS (Anatomic shell System)
- New seat belt slot fixed to the shell
- Velour covering
- No slip cushion
- Technical insert
- 5 seat belt opening
- Lateral fixing
- Weight: 8,200 kg

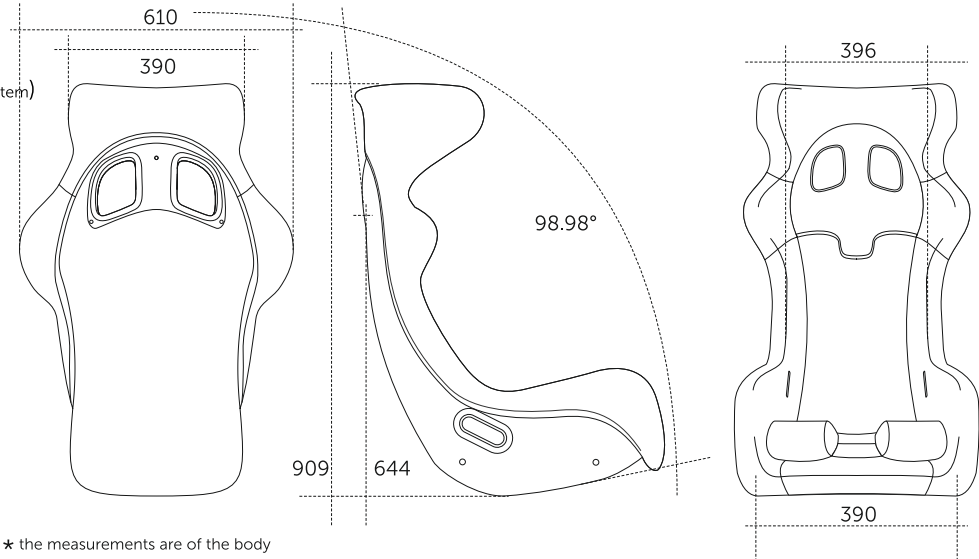

★ the measurements are of the body therefore without sponge



ATAC 0318

Stell side brackets for all other seats

atech
racing seats



atech
racing seats

3002 022A
1A 8987-2001
CPR

AMBER

PERFORMANCE SHP ATSP020

Complies with Fia Standard 8855-1999



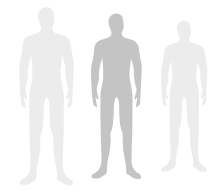

Sizes: L

First Atech Seat, is a very good compromise between dimensional optimization of Extreme and North Seats and a wider base for larger body, suitable for rider up to 185 cm.

- Gel-coated fiberglass shell
- Side head protection
- Preformed shell with ASS (Anatomic shell System)
- New seat belt slot fixed to the shell
- Velour covering
- No slip cushion
- Technical insert
- 5 seat belt opening
- Lateral fixing
- Weight: 8,400 kg

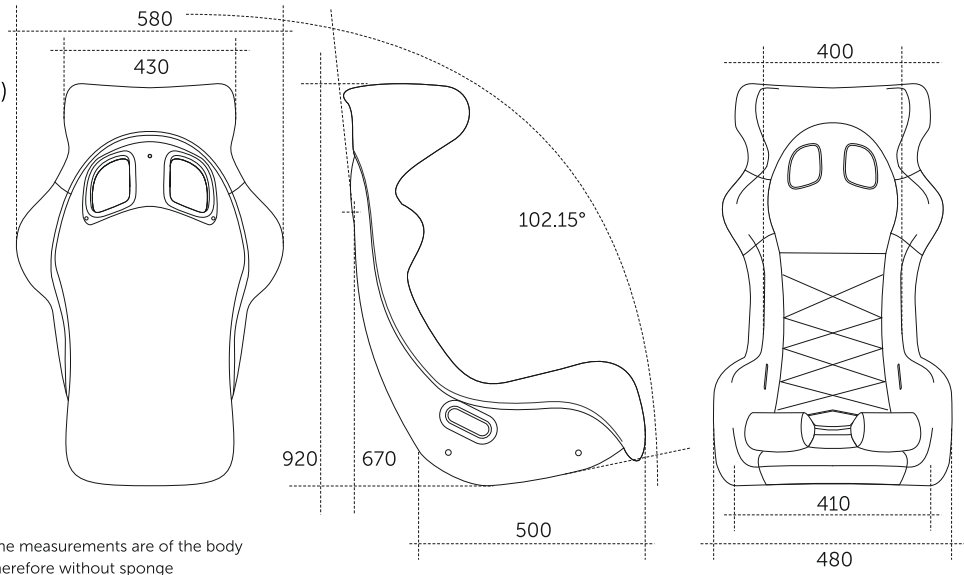

★ the measurements are of the body therefore without sponge



ATAC 0318

Stell side brackets for all other seats

TARGET ATS015

Complies with Fia Standard 8855-1999



NEW DESIGN HI-LINE



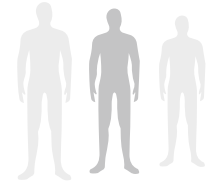

Sizes: L

Seat with best performances, appreciated for versatile use, very good confort, it is without side head protection, so it can be used also in very narrow cockpits.

- Gel-coated fiberglass shell preformed shell with ASS (Anatomic shell System)
- New seat belt slot fixed to the shell
- Velour covering
- Technical insert
- No slip cushion pre-shaped for easy use for seat
- Belt - 5 seat belt opening
- Lateral fixing
- Weight: 7,300 kg

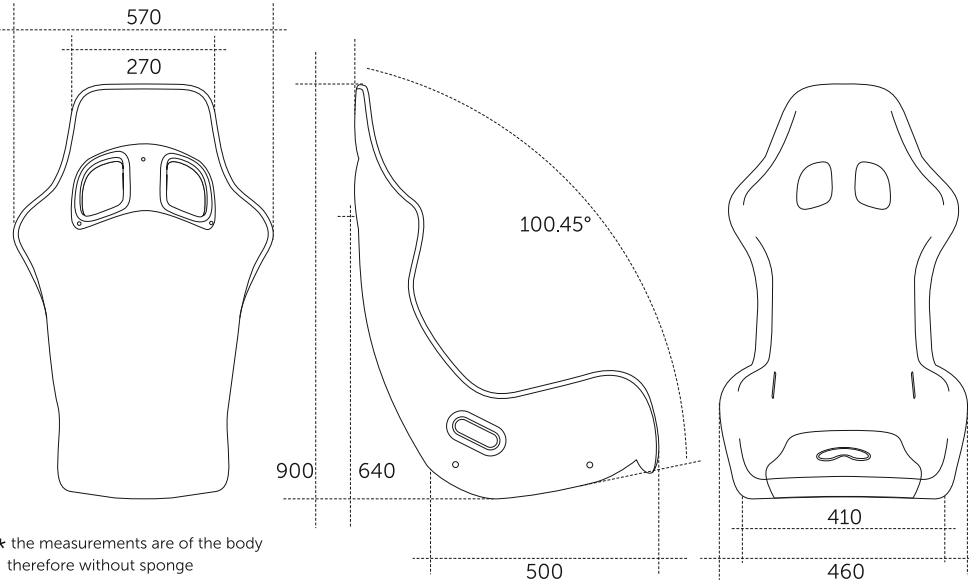

★ the measurements are of the body therefore without sponge



ATAC 0318

Stell side brackets for all other seats

TARGET XL ATS016

Complies with Fia Standard 8855-1999



NEW DESIGN HI-LINE



RACING SEATS



MANUFACTURER: ATECH
 MODEL: TARGET XL
 FOML NO.: CS-247.12
 FIA STANDARD: 8855-1999

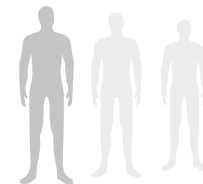

Sizes: **XL**

Seat with best performances, appreciated for its versatility, very good confort, designed without side-head protection, ideal for tall and robust drivers.

- Gel-coated fiberglass shell preformed shell with ASS (Anatomic shell System)
- New seat belt slot fixed to the shell
- Velour fabric covering
- Technical insert
- Seat with anti-slip cushion pre-shaped for easy use
- Belt - 5 seat belt opening
- Lateral fixing
- Weight: 7,890 kg

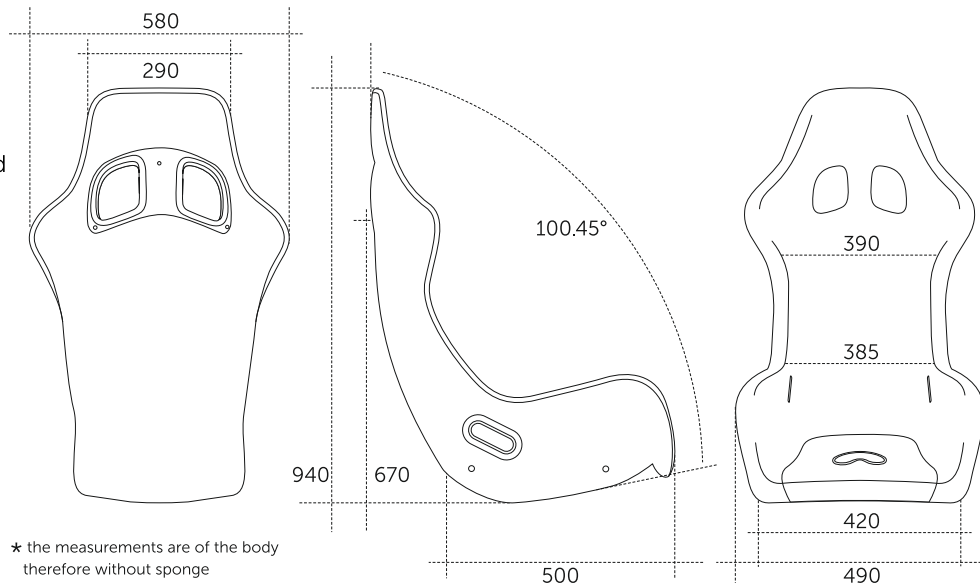

★ the measurements are of the body therefore without sponge



ATAC 0318

Stell side brackets for all other seats



RSR ATS010

Complies with Fia Standard 8855-1999



NEW DESIGN HI-LINE



RACING SEATS

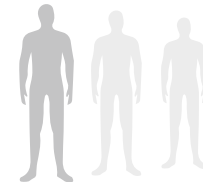

Sizes: XL

Very similar features to Target seat, technical and simple design.

- Gel-coated fiberglass shell
- Preformed shell with ASS
(Anatomic shell System)
- New seat belt slot fixed to the shell
- Velour covering
- Standard technical inserts
- No slip cushion
- 5 seat belt opening
- Lateral fixing
- Weight: 7,300 kg

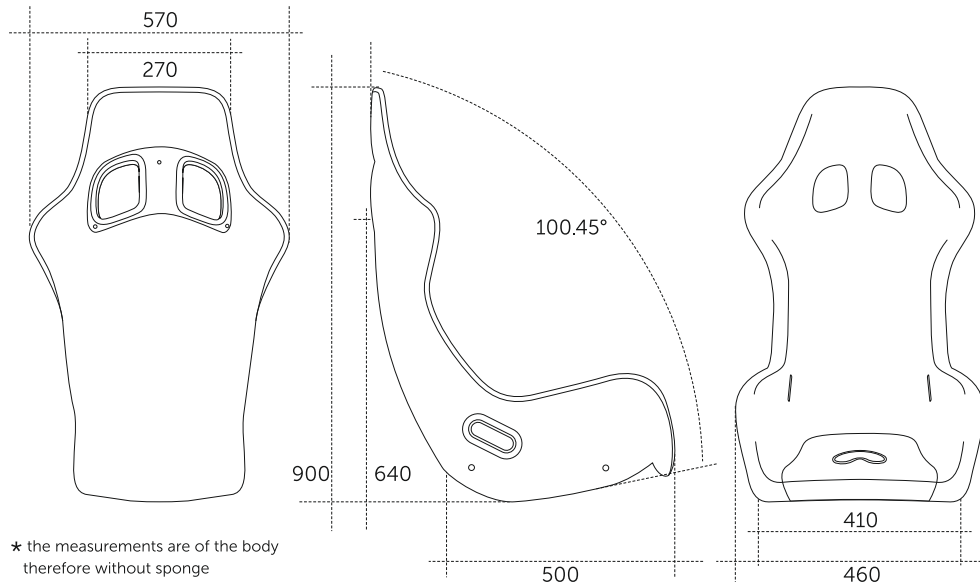

★ the measurements are of the body therefore without sponge



ATAC 0318

Stell side brackets for all other seats

EASY SEAT ATS 005

Complies with Fia Standard 8855-1999



NEW DESIGN



RACING SEATS

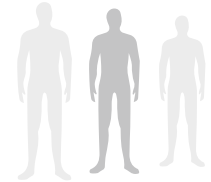

Sizes: L

Entry level price for an high quality seat, thanks to the vtr shell base with leg raise and two-tone finish.

- Entry level seat
- Gel-coated fiberglass shell
- 5 seat belt opening
- Lateral fixing
- Weight: 7,000 kg

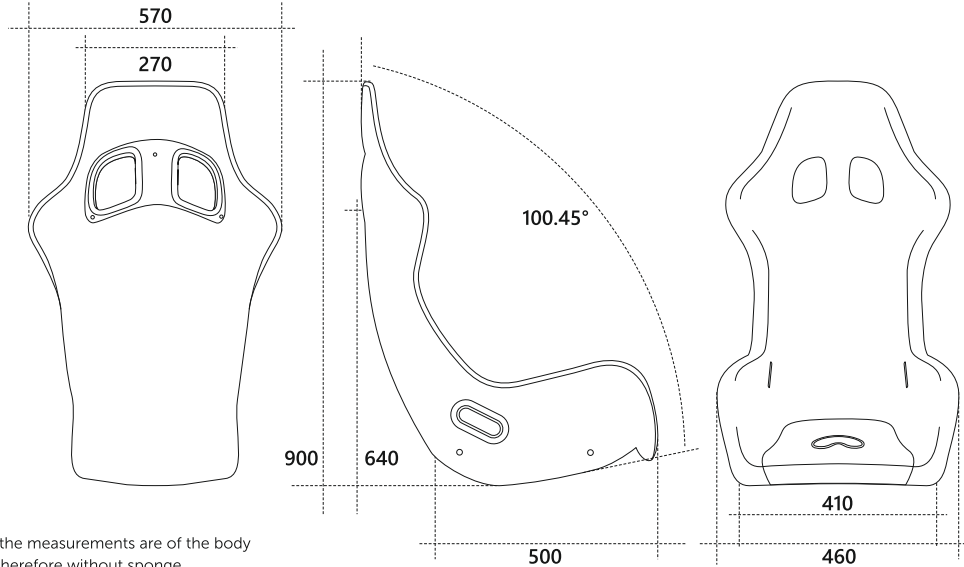

★ the measurements are of the body therefore without sponge



ATAC 0318

Stell side brackets for all other seats



RAID 4X4 ATSS 045

Complies with Fia Standard 8855-1999



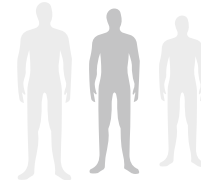

Sizes: L

Based on the RSR Seat, due to the Sky covering it's perfect for offroad competition cars and easy to clean.

- Gel-coated fiberglass shell
- Preformed shell with ASS
(Anatomic shell System)
- New seat belt slot fixed to the shell
- Sky covering
- Standard technical insert
- No clip cushion
- 5 seat belt opening
- Lateral fixing
- Weight: 9,300 kg

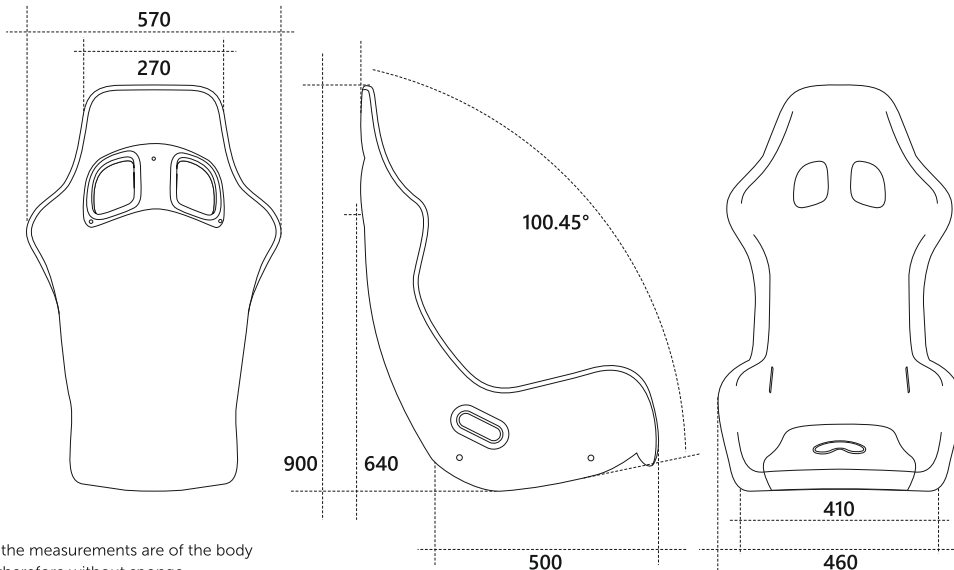

★ the measurements are of the body therefore without sponge



ATAC 0318

Stell side brackets for all other seats





atech
racing
BALLETTI
Technique

atech

atech

Max

NEW LINE
CROSS SEATS





CROSS ATS002

Complies with Fia Standard 8855-1999



NEW DESIGN



* Also available without padding
(on request)

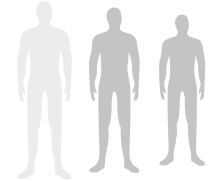

Sizes: **L/M**

Seat born the profile is taken to the extreme form to be placed in very limited cockpits, suitable for rider up to 180 cm.

- Gel-coated fiberglass shell
- Preformed shell with ASS
(Anatomic shell System)
- New seat belt slot fixed to the shell
- Technical insert
- 5 seat belt opening
- Lateral fixing
- Weight: 8,200 kg

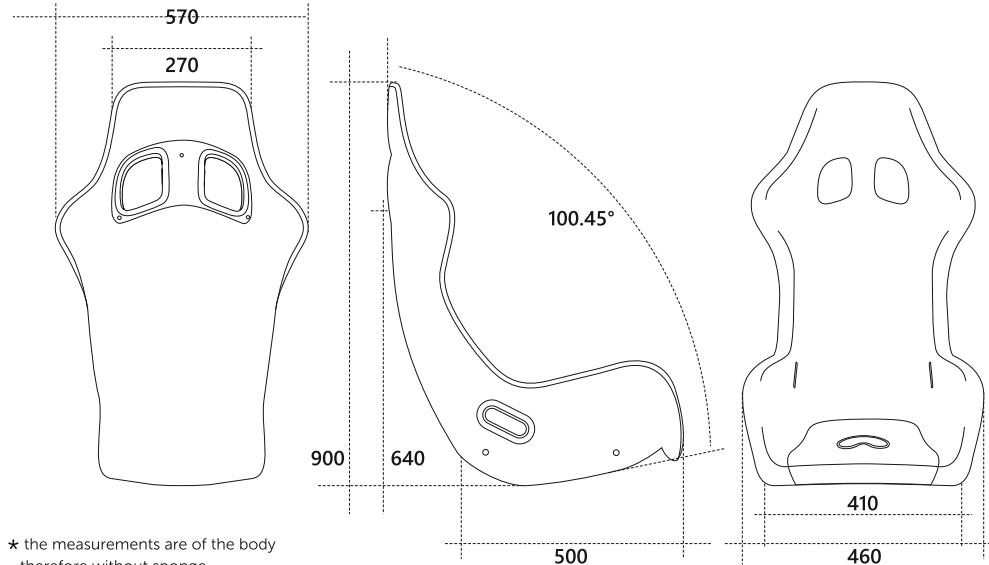

★ the measurements are of the body therefore without sponge



ATAC 0318

Stell side brackets for all other seats

EXTREME CROSS ATSPEX032CRS

Complies with Fia Standard 8855-1999



* Also available without padding
(on request)

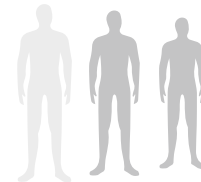

Sizes: **L/M**

Seat born the profile is taken to the extreme form to be placed in very limited cockpits, suitable for rider up to 180/185 cm.

- Gel-coated fiberglass shell
- Side head protection
- Preformed shell with ASS (Anatomic shell System)
- New seat belt slot fixed to the shell
- Technical insert
- 5 seat belt opening
- Lateral fixing
- Weight: 8,200 kg

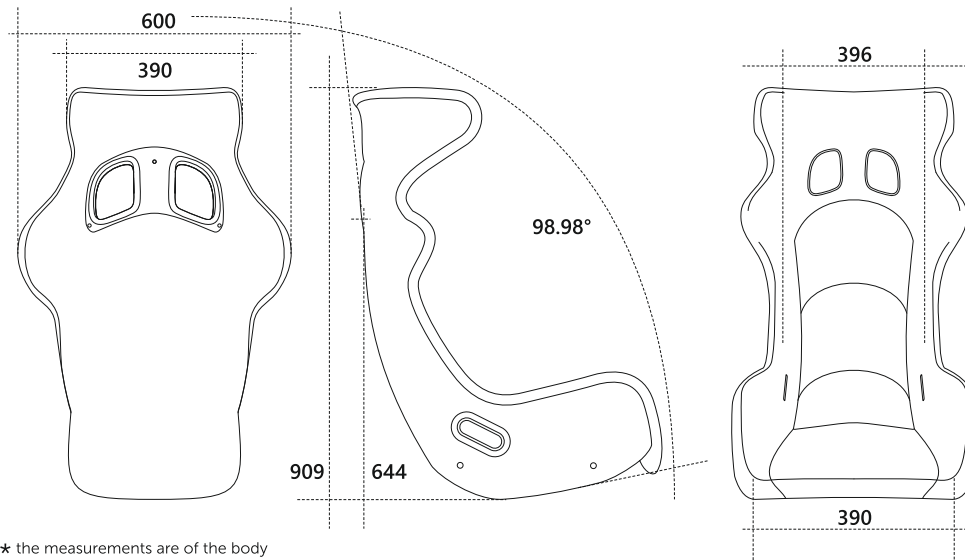

★ the measurements are of the body therefore without sponge



ATAC 0318

Stell side brackets for all other seats

RACING GAME ATSIM 020



NEW DESIGN



GAME SEATS

Get ready to become a champion train with our new gaming seat.





BELTS



HARNESSES

ATHA 0304
ATHA 0306

A complete high quality Harnesses range to be able to satisfy any costumers requests.



ATHA 0304



FIA 8853-2016 (R5/WRC)
HARNESSES 6 POINT 2/3" HANS
2 ALLUMINUM
ADJUSTERS + 2 STEEL
ADJUSTERS LIGHT



ATHA 0306



FIA 8853-2016 (R5/WRC)
HARNESSES 6 POINT 2/2" HANS
4 ALLUMINUM
ADJUSTERS ULTRA LIGHT
AVAILABLE ON REQUEST



* only on request minimum 10 pieces



STEERING WHEELS



STEERING WHEELS

A full range of steering wheels for all motorsport applications



ATVO 0104

Steering wheels 2 spokes
Diam. 330mm - 90mm Deep
Suede covered



330mm



Flat



350mm



Flat



350mm



90 mm



350mm



65 mm

ATVO 0100

Steering wheels 3 spokes
Diam. 330mm
Suede covered

ATVO 0101

Steering wheels 3 spokes
Diam. 350mm
Suede covered

ATVO 0102

Steering wheels 3 spokes
Diam. 350mm - 90mm Deep
Suede covered

ATVO 0103

Steering wheels 3 spokes
Diam. 350mm - 65mm Deep
Suede covered



ACCESSORIES

ATBC 0300

Canned circular key ring to be included in the spare wheel available for wheel from 13 to 18 inches



ATBO 0113

Codriver Bag with connections for fixing a roll-bar





ATBP 0300

New bag atech fashionable,
perfect to hold the racing suit
and practice time and
comfortable.



ATBS 001

SPORT BAG

Take everything you need with you with this practical and compact bag Atech. The side pocket and the front compartment with zip closure allow you to have the essential items always.

Capacity 45 litres
Zip Closure
Diameter 32 cm
length 60 cm

NEW DESIGN



GIADA AUTO
CHIAVARI



Hosteria della
Luna Piana

Località Brani 7 - S. Stefano d'Aveto
Tel. 0185 83382

PASTICCERIA
MARRE'
Wine Bar

BOX HOUSE

Your Mobility Solution

Gecar GT Motor

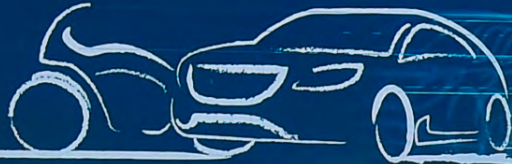

CONCESSIONARIA UFFICIALE E SERVICE



VEICOLI COMMERCIALI



SERVICE



36° Rally della Lanterna
4° Rally Val d'Aveto

Automobile Club
GENOVA
BOX HOUSE

1



IMMOBILIARE
CARDANI

DAL 1861



BOX HOUSE

**PASTICCERIA
MARRE'**
Wine Bar
Via 20, Santo Stefano d'Aveto (GE) - Tel. 0185 88071

**Hosteria della
Luna Piena**
Santo Stefano d'Aveto

Specialcar S

MINI

Specialcar

1

**36° Rally della Lanterna
4° Rally Val d'Aveto**

Automobile Club **GENOVA BOX HOUSE**

PASTICCERIA MARRE' | **GIADA AUTO CHIAVARI** | **Hosteria della Luna Piena**



ATRC 0200

CAMEL BAG

Water bag holder with connections for seats.



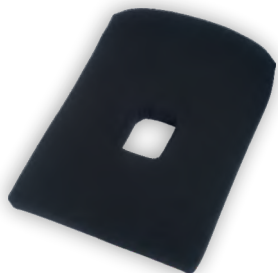

ATRC 0253

Rice sitting rigid
anatomic all Carbon Seats



ATRC 0251

Rice sitting rigid
anatomic seat Estreme S2



ATHA 0300

Harness pads



ATPC 0105

Raid/Rally helmet case
with light glove compartment



ATPC 0107

Raid/Rally helmet case
with light glove compartment



ATIC 001

Hook L: 23 cm



ATRC 0252
Anatomic complete kit adapter
Carbon seat



ATRC 0250
Anatomic complete kit adapter
Standard seat



NEW
aint

atech
racing

Max Verstappen

atech
racing
Max Verstappen

atech
racing

HUOT

atech
racing

88



3

MS MUNARETTO

KONIG PRINT

ITALGRAFICA

ELLEGI TRENTO

KPS TECH

MS

NS

ZINCATURA

Guariento atech

atech

ZINCATURA

Guariento

PIRELLI

PIRELLI



ATSU 0290

Atech seat support for showroom





AT BRK-18L

Stell side brackets for use only with RS/RS8/LHT carbon seats



ATAC 0318

Stell side brackets for all other seats FIA 8855-1999



BRK C-RS

Stell side brackets for use only with RS/RS7 carbon seats



ATAL 0318

Alluminium brackets



ATRC 0202

(con protezioni)

Black tear-resistant seat cover



ATRC 0201

(senza protezioni)

Black tear-resistant seat cover







FRED. OLSEN
Express

www.fredolsen.es

PIRELLI

PIRELLI

atech

atech

atech

atech

atech

atech

atech

ot.ca
Instalaciones S.L.

ramóngarcía

YUASA
Bermúdez
SUMINISTROS DE POU...

CLARAX
CLARAX

WWW

ot.ca
Instalaciones S.L.

ramóngarcía

HYUNDAI

PIRELLI

YUASA
Bermúdez



T-SHIRT ATSW 001

T-SHIRT 100% Cotton 165gr/mq
single jersey - Soft to the touch.

Colors: White/Black/Blue/Grey

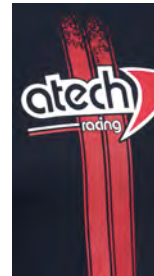



ATWS 001 - T-SHIRT black



ATWS 001 - T-SHIRT grey



ATTW 002 - Shirt short sleeve (1color)
ATTW 004 - Shirt short sleeve (1color)



RACE HAT ATRH 001

100% Brushed cotton
in Summer and Winter version.

Colors: White/Black/Bicolored



ATRH 002



ATRH 001

